



# RF Power Field Effect Transistors

## N-Channel Enhancement-Mode Lateral MOSFETs

Designed for W-CDMA base station applications with frequencies from 2110 to 2170 MHz. Suitable for TDMA, CDMA and multicarrier amplifier applications. To be used in Class AB for PCN - PCS/cellular radio and WLL applications.

- Typical 2-carrier W-CDMA Performance for  $V_{DD} = 28$  Volts,  $I_{DQ} = 500$  mA,  $f_1 = 2135$  MHz,  $f_2 = 2145$  MHz, Channel Bandwidth = 3.84 MHz, Adjacent Channels measured over 3.84 MHz Bandwidth at  $f_1 - 5$  MHz and  $f_2 + 5$  MHz, Distortion Products measured over a 3.84 MHz Bandwidth at  $f_1 - 10$  MHz and  $f_2 + 10$  MHz, Peak/Avg. = 8.3 dB @ 0.01% Probability on CCDF.
  - Output Power — 10 Watts Avg.
  - Efficiency — 23.5%
  - Gain — 15 dB
  - IM3 — -37.5 dBc
  - ACPR — -41 dBc
- Capable of Handling 5:1 VSWR, @ 28 Vdc, 2140 MHz, 45 Watts CW Output Power

### Features

- Internally Matched for Ease of Use
- High Gain, High Efficiency and High Linearity
- Integrated ESD Protection
- Designed for Maximum Gain and Insertion Phase Flatness
- Excellent Thermal Stability
- Characterized with Series Equivalent Large-Signal Impedance Parameters
- Low Gold Plating Thickness on Leads, 40 $\mu$ " Nominal.
- RoHS Compliant
- In Tape and Reel. R3 Suffix = 250 Units per 32 mm, 13 Inch Reel.

**MRF21045LR3**  
**MRF21045LSR3**

**2110-2170 MHz, 45 W, 28 V**  
**LATERAL N-CHANNEL**  
**RF POWER MOSFETs**

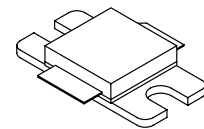

**CASE 465E-04, STYLE 1**  
**NI-400**  
**MRF21045LR3**

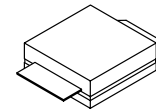

**CASE 465F-04, STYLE 1**  
**NI-400S**  
**MRF21045LSR3**

**Table 1. Maximum Ratings**

Rating	Symbol	Value	Unit
Drain-Source Voltage	$V_{DSS}$	-0.5, +65	Vdc
Gate-Source Voltage	$V_{GS}$	-0.5, +15	Vdc
Total Device Dissipation @ $T_C = 25^\circ\text{C}$ Derate above $25^\circ\text{C}$	$P_D$	105 0.60	W W/ $^\circ\text{C}$
Storage Temperature Range	$T_{stg}$	- 65 to +150	$^\circ\text{C}$
Case Operating Temperature	$T_C$	150	$^\circ\text{C}$
Operating Junction Temperature	$T_J$	200	$^\circ\text{C}$

**Table 2. Thermal Characteristics**

Characteristic	Symbol	Value (1)	Unit
Thermal Resistance, Junction to Case	$R_{\theta JC}$	1.65	$^\circ\text{C}/\text{W}$

**Table 3. ESD Protection Characteristics**

Test Conditions	Class
Human Body Model	1 (Minimum)
Machine Model	M2 (Minimum)

1. Refer to AN1955, *Thermal Measurement Methodology of RF Power Amplifiers*. Go to <http://www.freescale.com/rf>. Select Documentation/Application Notes - AN1955.

**Table 4. Electrical Characteristics** ( $T_C = 25^\circ\text{C}$  unless otherwise noted)

Characteristic	Symbol	Min	Typ	Max	Unit
<b>Off Characteristics</b>					
Drain-Source Breakdown Voltage ( $V_{GS} = 0\text{ Vdc}$ , $I_D = 100\ \mu\text{Adc}$ )	$V_{(BR)DSS}$	65	—	—	Vdc
Zero Gate Voltage Drain Current ( $V_{DS} = 28\text{ Vdc}$ , $V_{GS} = 0\text{ Vdc}$ )	$I_{DSS}$	—	—	10	$\mu\text{Adc}$
Gate-Source Leakage Current ( $V_{GS} = 5\text{ Vdc}$ , $V_{DS} = 0\text{ Vdc}$ )	$I_{GSS}$	—	—	1	$\mu\text{Adc}$
<b>On Characteristics (DC)</b>					
Gate Threshold Voltage ( $V_{DS} = 10\text{ Vdc}$ , $I_D = 100\ \mu\text{Adc}$ )	$V_{GS(th)}$	2	—	4	Vdc
Gate Quiescent Voltage ( $V_{DS} = 28\text{ Vdc}$ , $I_D = 500\text{ mAdc}$ )	$V_{GS(Q)}$	3	3.9	5	Vdc
Drain-Source On-Voltage ( $V_{GS} = 10\text{ Vdc}$ , $I_D = 1\text{ Adc}$ )	$V_{DS(on)}$	—	0.19	0.21	Vdc
Forward Transconductance ( $V_{DS} = 10\text{ Vdc}$ , $I_D = 1\text{ Adc}$ )	$g_{fs}$	—	3	—	S
<b>Dynamic Characteristics (1)</b>					
Reverse Transfer Capacitance ( $V_{DS} = 28\text{ Vdc}$ , $V_{GS} = 0$ , $f = 1\text{ MHz}$ )	$C_{rss}$	—	1.8	—	pF
<b>Functional Tests</b> (In Freescale Test Fixture, 50 ohm system) 2-carrier W-CDMA. Peak/Avg. = 8.3 dB @ 0.01% Probability on CCDF.					
Common-Source Amplifier Power Gain ( $V_{DD} = 28\text{ Vdc}$ , $P_{out} = 10\text{ W Avg.}$ , $I_{DQ} = 500\text{ mA}$ , $f_1 = 2112.5\text{ MHz}$ , $f_2 = 2122.5\text{ MHz}$ and $f_1 = 2157.5\text{ MHz}$ , $f_2 = 2167.5\text{ MHz}$ )	$G_{ps}$	13.5	15	—	dB
Drain Efficiency ( $V_{DD} = 28\text{ Vdc}$ , $P_{out} = 10\text{ W Avg.}$ , $I_{DQ} = 500\text{ mA}$ , $f_1 = 2112.5\text{ MHz}$ , $f_2 = 2122.5\text{ MHz}$ and $f_1 = 2157.5\text{ MHz}$ , $f_2 = 2167.5\text{ MHz}$ )	$\eta$	21	23.5	—	%
Third Order Intermodulation Distortion ( $V_{DD} = 28\text{ Vdc}$ , $P_{out} = 10\text{ W Avg.}$ , $I_{DQ} = 500\text{ mA}$ , $f_1 = 2112.5\text{ MHz}$ , $f_2 = 2122.5\text{ MHz}$ and $f_1 = 2157.5\text{ MHz}$ , $f_2 = 2167.5\text{ MHz}$ ; IM3 measured over 3.84 MHz Bandwidth at $f_1 - 10\text{ MHz}$ and $f_2 + 10\text{ MHz}$ .)	IM3	—	-37.5	-35	dBc
Adjacent Channel Power Ratio ( $V_{DD} = 28\text{ Vdc}$ , $P_{out} = 10\text{ W Avg.}$ , $I_{DQ} = 500\text{ mA}$ , $f_1 = 2112.5\text{ MHz}$ , $f_2 = 2122.5\text{ MHz}$ and $f_1 = 2157.5\text{ MHz}$ , $f_2 = 2167.5\text{ MHz}$ ; ACPR measured over 3.84 MHz Bandwidth at $f_1 - 5\text{ MHz}$ and $f_2 + 5\text{ MHz}$ .)	ACPR	—	-41	-38	dBc
Input Return Loss ( $V_{DD} = 28\text{ Vdc}$ , $P_{out} = 10\text{ W Avg.}$ , $I_{DQ} = 500\text{ mA}$ , $f_1 = 2112.5\text{ MHz}$ , $f_2 = 2122.5\text{ MHz}$ and $f_1 = 2157.5\text{ MHz}$ , $f_2 = 2167.5\text{ MHz}$ )	IRL	—	-12	-9	dB

1. Part is internally matched both on input and output.

(continued)

**Table 4. Electrical Characteristics** ( $T_C = 25^\circ\text{C}$  unless otherwise noted) (continued)

Characteristic	Symbol	Min	Typ	Max	Unit
<b>Functional Tests</b> (In Freescale Test Fixture, 50 ohm system) — continued					
Two-Tone Common-Source Amplifier Power Gain ( $V_{DD} = 28\text{ Vdc}$ , $P_{out} = 45\text{ W PEP}$ , $I_{DQ} = 500\text{ mA}$ , $f_1 = 2110\text{ MHz}$ , $f_2 = 2120\text{ MHz}$ and $f_1 = 2160\text{ MHz}$ , $f_2 = 2170\text{ MHz}$ )	$G_{ps}$	—	14.9	—	dB
Two-Tone Drain Efficiency ( $V_{DD} = 28\text{ Vdc}$ , $P_{out} = 45\text{ W PEP}$ , $I_{DQ} = 500\text{ mA}$ , $f_1 = 2110\text{ MHz}$ , $f_2 = 2120\text{ MHz}$ and $f_1 = 2160\text{ MHz}$ , $f_2 = 2170\text{ MHz}$ )	$\eta$	—	36	—	%
Intermodulation Distortion ( $V_{DD} = 28\text{ Vdc}$ , $P_{out} = 45\text{ W PEP}$ , $I_{DQ} = 500\text{ mA}$ , $f_1 = 2110\text{ MHz}$ , $f_2 = 2120\text{ MHz}$ and $f_1 = 2160\text{ MHz}$ , $f_2 = 2170\text{ MHz}$ )	IMD	—	-30	—	dBc
Two-Tone Input Return Loss ( $V_{DD} = 28\text{ Vdc}$ , $P_{out} = 45\text{ W PEP}$ , $I_{DQ} = 500\text{ mA}$ , $f_1 = 2110\text{ MHz}$ , $f_2 = 2120\text{ MHz}$ and $f_1 = 2160\text{ MHz}$ , $f_2 = 2170\text{ MHz}$ )	IRL	—	-12	—	dB
$P_{out}$ : 1 dB Compression Point ( $V_{DD} = 28\text{ Vdc}$ , $I_{DQ} = 500\text{ mA}$ , $f = 2170\text{ MHz}$ )	P1dB	—	50	—	W

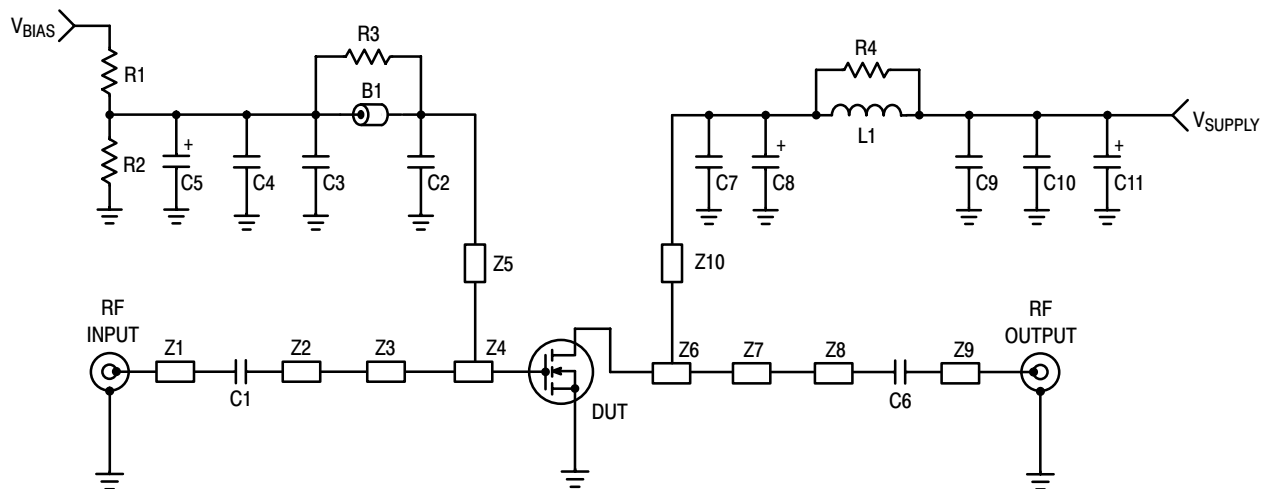

Z1, Z9	0.750" x 0.084" Transmission Line	Board	0.030" Glass Teflon <sup>®</sup> ,
Z2	0.160" x 0.084" Transmission Line	PCB	Keene GX-0300-55-22, $\epsilon_r = 2.55$
Z3	1.195" x 0.176" Transmission Line		Etched Circuit Boards
Z4	0.125" x 0.320" Transmission Line		MRF21045 Rev. 3, CMR
Z5	1.100" x 0.045" Transmission Line		
Z6	0.442" x 0.650" Transmission Line		
Z7	0.490" x 0.140" Transmission Line		
Z8	0.540" x 0.084" Transmission Line		
Z10	0.825" x 0.055" Transmission Line		

**Figure 1. MRF21045LR3(SR3) Test Circuit Schematic**

**Table 5. MRF21045LR3(SR3) Component Designations and Values**

Designators	Description
B1	Short Ferrite Bead, Fair Rite, #2743019447
C1, C2, C6	43 pF Chip Capacitors, ATC #100B430JCA500X
C7	5.6 pF Chip Capacitor, ATC #100B5R6JCA500X
C3, C9	1000 pF Chip Capacitors, ATC #100B102JCA500X
C4, C10	0.1 $\mu$ F Chip Capacitors, Kemet #CDR33BX104AKWS
C5	1.0 $\mu$ F Tantalum Chip Capacitor, Kemet #T491C105M050
C8	10 $\mu$ F Tantalum Chip Capacitor, Kemet #T495X106K035AS4394
C11	22 $\mu$ F Tantalum Chip Capacitor, Kemet #T491X226K035AS4394
L1	1 Turn, #20 AWG, 0.100" ID
N1, N2	Type N Flange Mounts, Omni Spectra #3052-1648-10
R1	1.0 k $\Omega$ , 1/8 W Chip Resistor
R2	180 k $\Omega$ , 1/8 W Chip Resistor
R3, R4	10 $\Omega$ , 1/8 W Chip Resistors

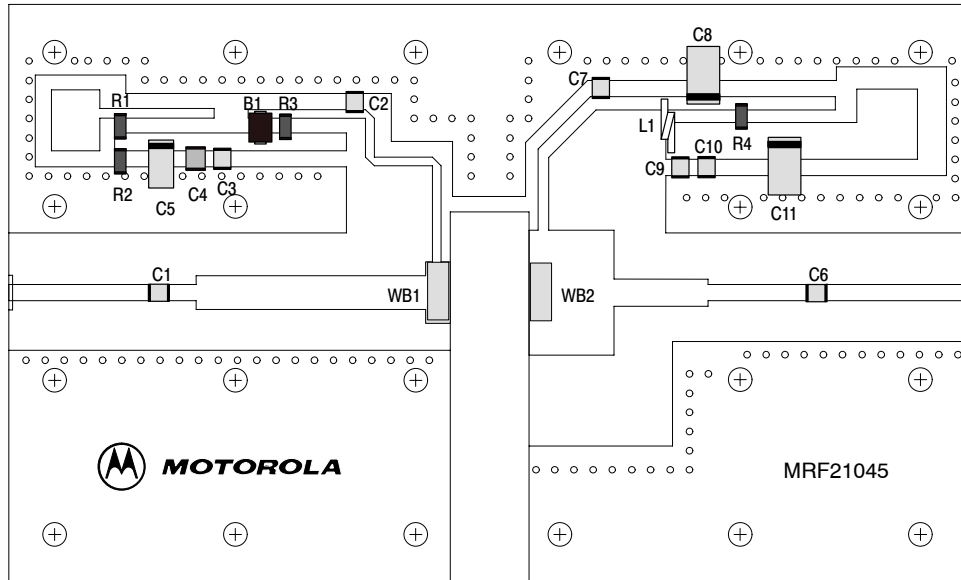

Freescale has begun the transition of marking Printed Circuit Boards (PCBs) with the Freescale Semiconductor signature/logo. PCBs may have either Motorola or Freescale markings during the transition period. These changes will have no impact on form, fit or function of the current product.

**Figure 2. MRF21045LR3(SR3) Test Circuit Component Layout**

## TYPICAL CHARACTERISTICS

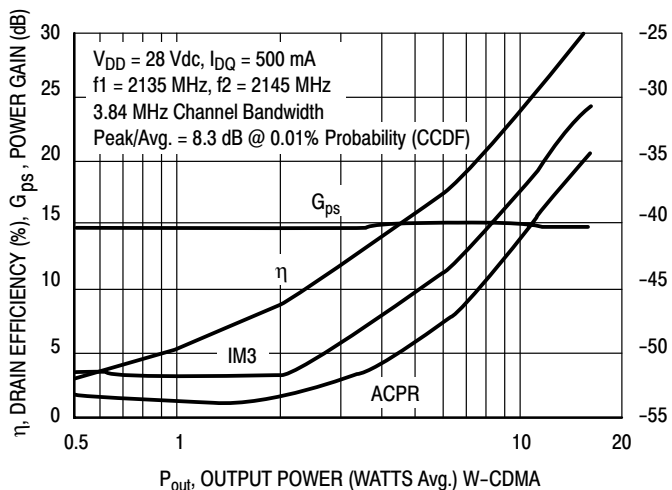

**Figure 3. 2-Carrier W-CDMA ACPR, IM3, Power Gain and Drain Efficiency versus Output Power**

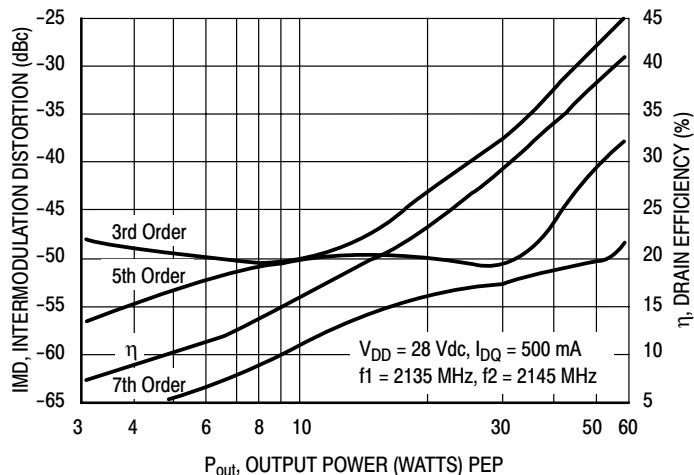

**Figure 4. Intermodulation Distortion Products versus Output Power**

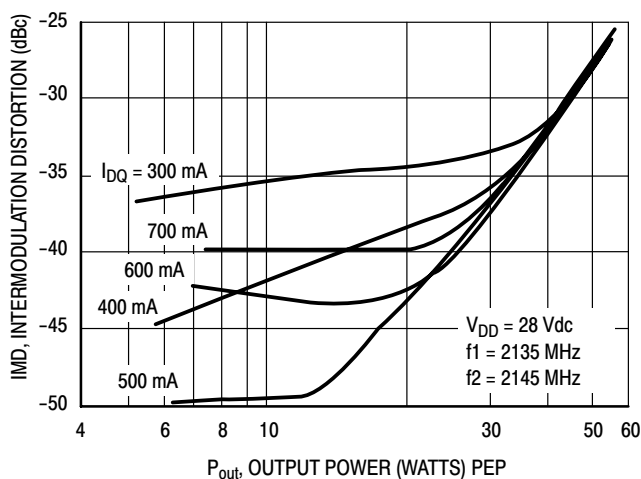

**Figure 5. Intermodulation Distortion versus Output Power**

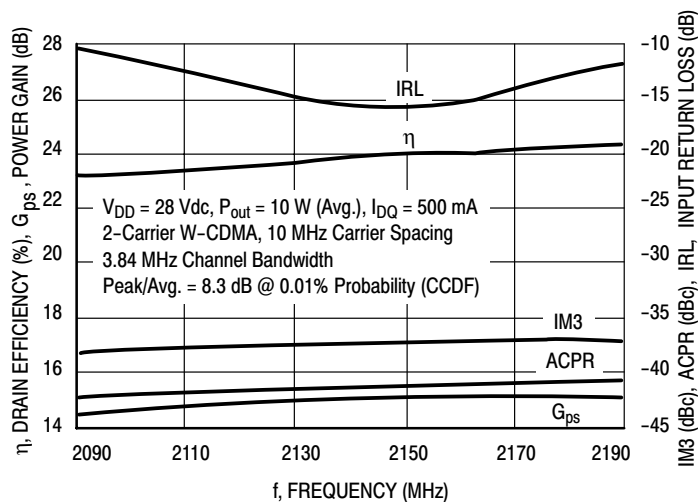

**Figure 6. 2-Carrier W-CDMA Broadband Performance**

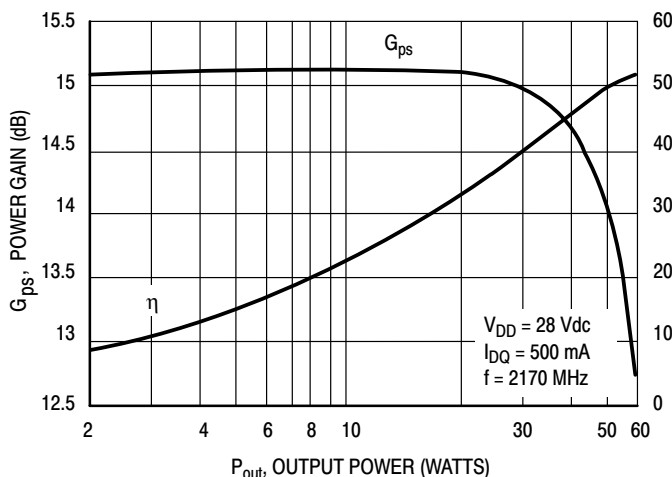

**Figure 7. CW Performance**

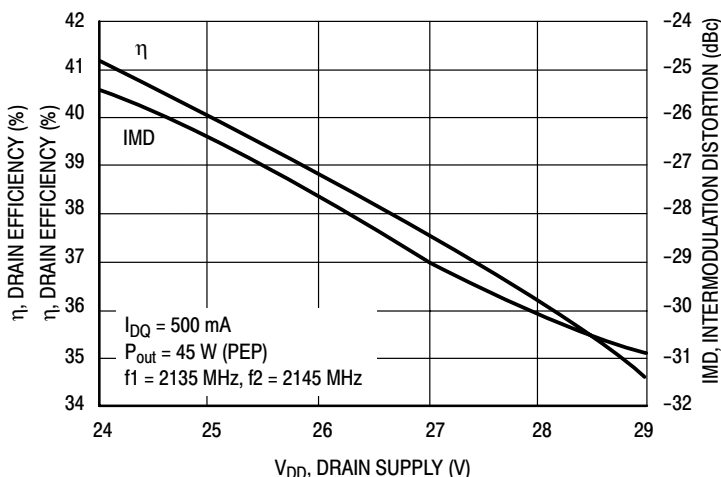

**Figure 8. Two-Tone Intermodulation Distortion and Drain Efficiency versus Drain Supply**

## TYPICAL CHARACTERISTICS

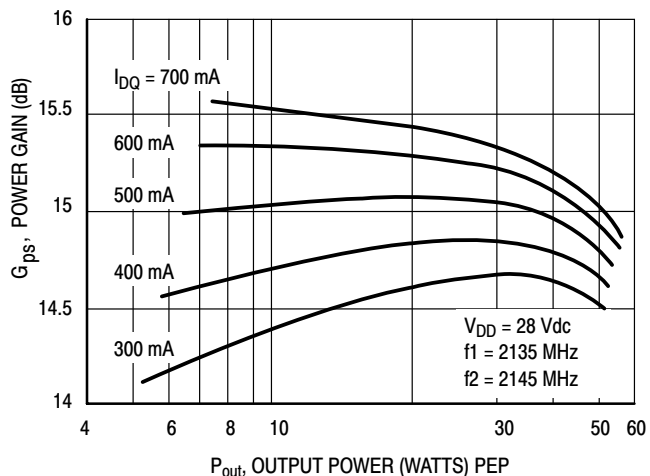

Figure 9. Two-Tone Power Gain versus Output Power

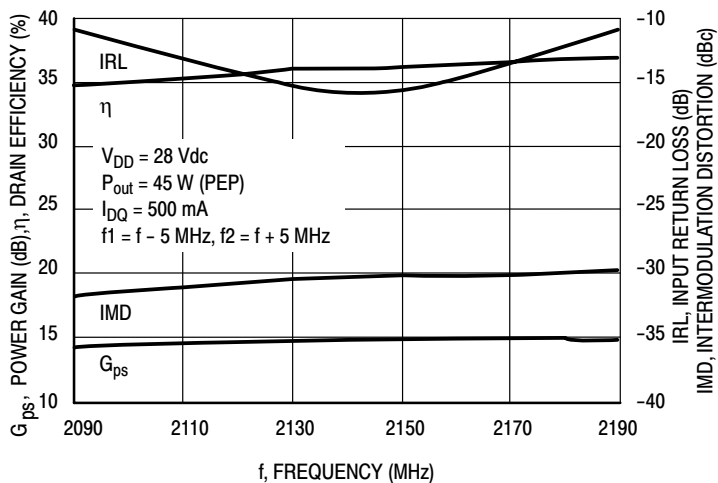

Figure 10. Two-Tone Broadband Performance

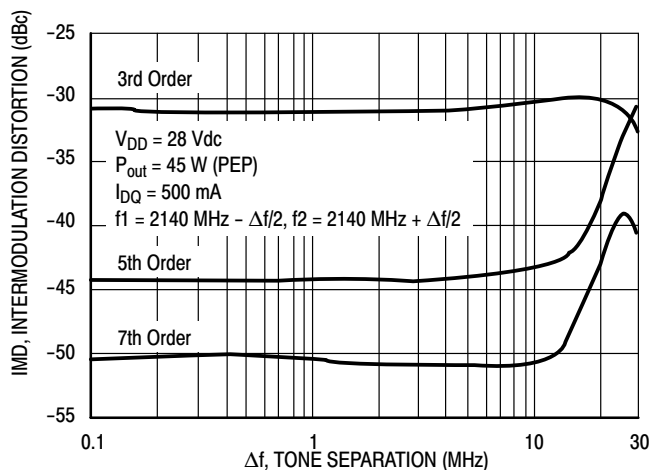

Figure 11. Intermodulation Distortion Products versus Two-Tone Spacing

## W-CDMA TEST SIGNAL

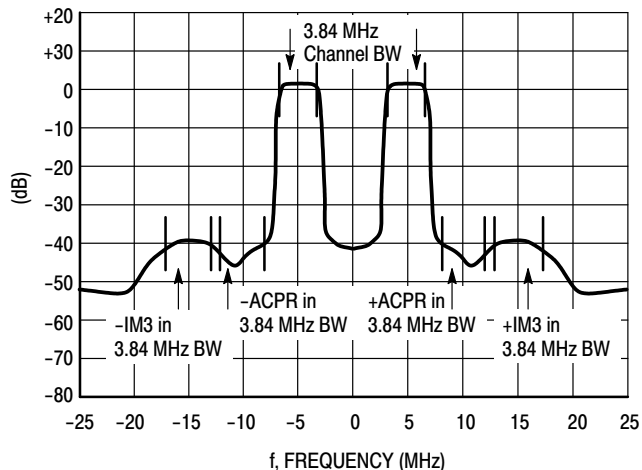
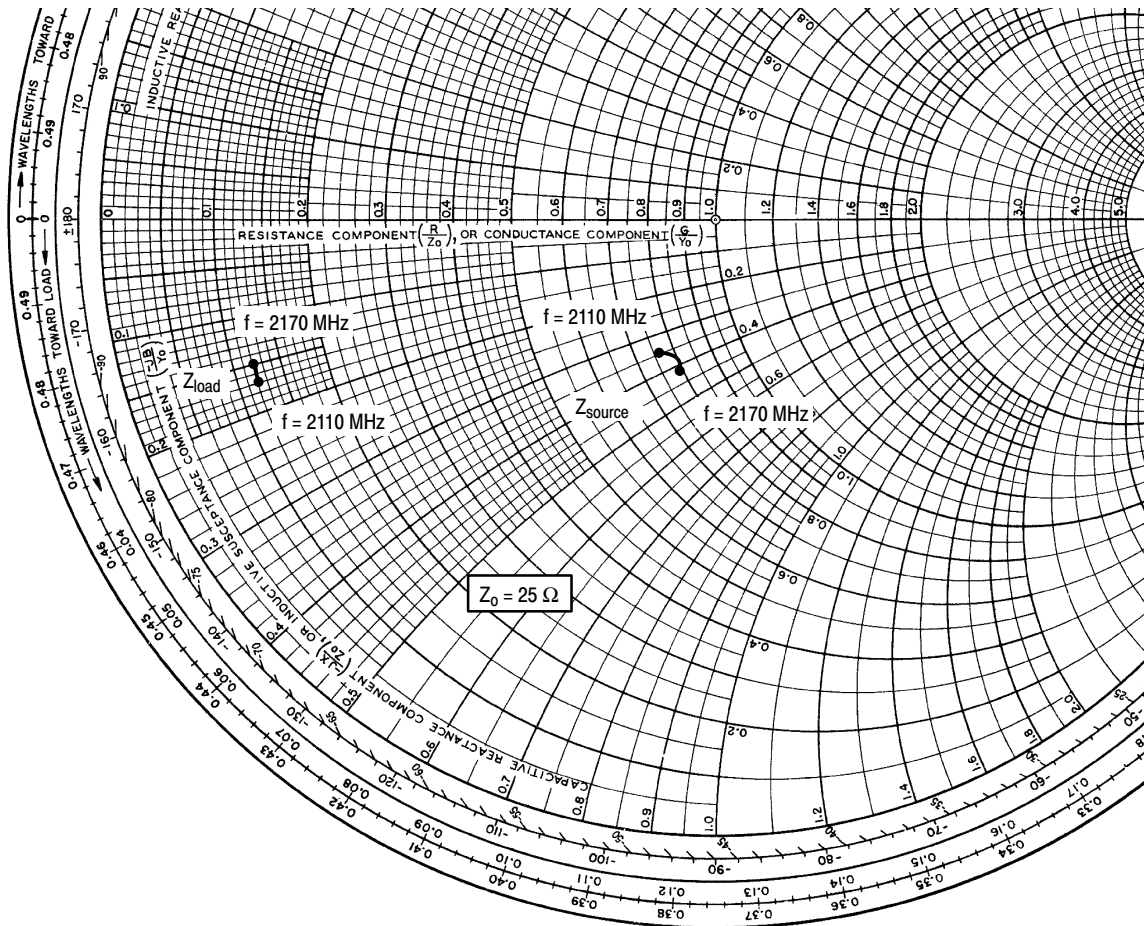

Figure 12. 2-Carrier W-CDMA Spectrum



$V_{DD} = 28 \text{ Vdc}$ ,  $I_{DQ} = 500 \text{ mA}$ ,  $P_{out} = 10 \text{ W Avg.}$

f MHz	$Z_{source}$ $\Omega$	$Z_{load}$ $\Omega$
2110	$18.88 - j8.86$	$3.11 - j4.18$
2140	$19.80 - j9.93$	$3.09 - j3.87$
2170	$19.68 - j10.44$	$3.12 - j3.72$

$Z_{source}$  = Test circuit impedance as measured from gate to ground.

$Z_{load}$  = Test circuit impedance as measured from drain to ground.

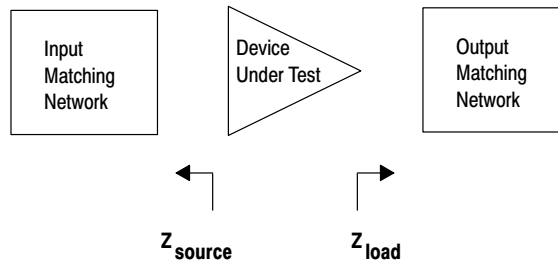

Figure 13. Series Equivalent Source and Load Impedance





# NOTES

# NOTES

## PACKAGE DIMENSIONS

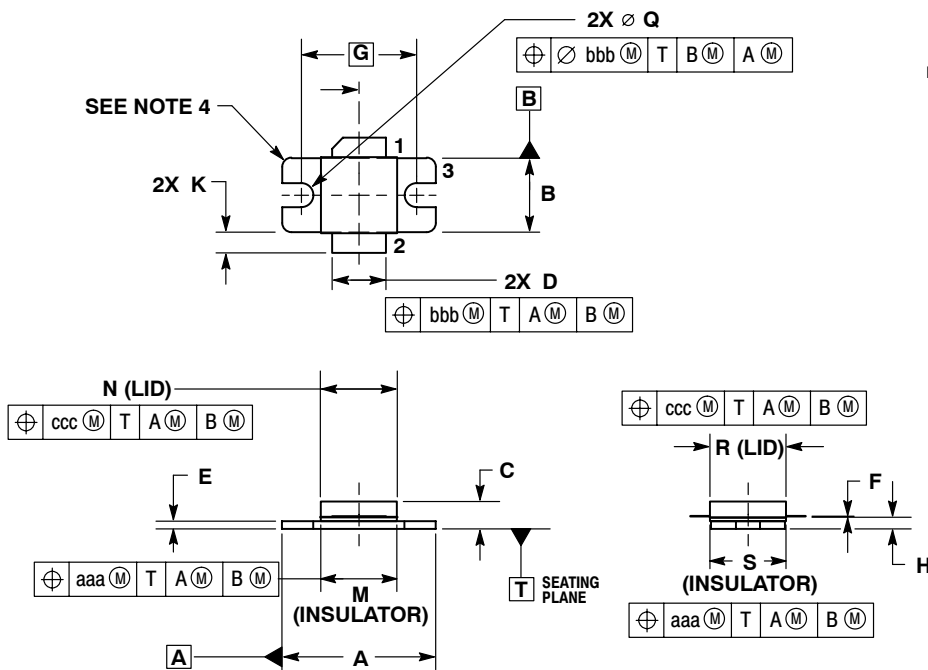

**CASE 465E-04  
ISSUE F  
NI-400  
MRF21045LR3**

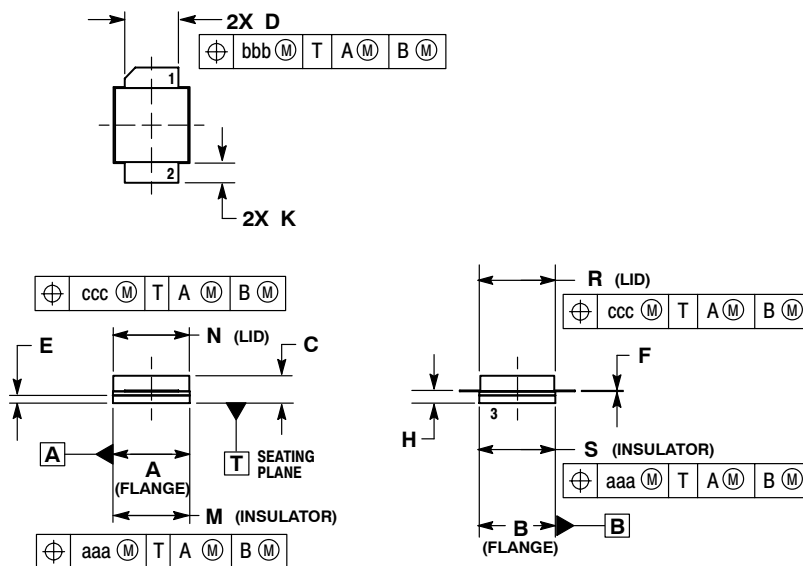

**CASE 465F-04  
ISSUE E  
NI-400S  
MRF21045LSR3**

- NOTES:
1. CONTROLLING DIMENSION: INCH.
  2. INTERPRET DIMENSIONS AND TOLERANCES PER ASME Y14.5M, 1994.
  3. DIMENSION H IS MEASURED 0.030 (0.762) AWAY FROM PACKAGE BODY.
  4. INFORMATION ONLY: CORNER BREAK (4X) TO BE .060±.005 (1.52±0.13) RADIUS OR .06±.005 (1.52±0.13) x 45° CHAMFER.

- NOTES:
1. CONTROLLING DIMENSION: INCH.
  2. INTERPRET DIMENSIONS AND TOLERANCES PER ASME Y14.5M-1994.
  3. DIMENSION H IS MEASURED 0.030 (0.762) AWAY FROM PACKAGE BODY.

## **How to Reach Us:**

### **Home Page:**

www.freescale.com

### **E-mail:**

support@freescale.com

### **USA/Europe or Locations Not Listed:**

Freescale Semiconductor  
Technical Information Center, CH370  
1300 N. Alma School Road  
Chandler, Arizona 85224  
+1-800-521-6274 or +1-480-768-2130  
support@freescale.com

### **Europe, Middle East, and Africa:**

Freescale Halbleiter Deutschland GmbH  
Technical Information Center  
Schatzbogen 7  
81829 Muenchen, Germany  
+44 1296 380 456 (English)  
+46 8 52200080 (English)  
+49 89 92103 559 (German)  
+33 1 69 35 48 48 (French)  
support@freescale.com

### **Japan:**

Freescale Semiconductor Japan Ltd.  
Headquarters  
ARCO Tower 15F  
1-8-1, Shimo-Meguro, Meguro-ku,  
Tokyo 153-0064  
Japan  
0120 191014 or +81 3 5437 9125  
support.japan@freescale.com

### **Asia/Pacific:**

Freescale Semiconductor Hong Kong Ltd.  
Technical Information Center  
2 Dai King Street  
Tai Po Industrial Estate  
Tai Po, N.T., Hong Kong  
+800 2666 8080  
support.asia@freescale.com

### **For Literature Requests Only:**

Freescale Semiconductor Literature Distribution Center  
P.O. Box 5405  
Denver, Colorado 80217  
1-800-441-2447 or 303-675-2140  
Fax: 303-675-2150  
LDCForFreescaleSemiconductor@hibbertgroup.com

Information in this document is provided solely to enable system and software implementers to use Freescale Semiconductor products. There are no express or implied copyright licenses granted hereunder to design or fabricate any integrated circuits or integrated circuits based on the information in this document.

Freescale Semiconductor reserves the right to make changes without further notice to any products herein. Freescale Semiconductor makes no warranty, representation or guarantee regarding the suitability of its products for any particular purpose, nor does Freescale Semiconductor assume any liability arising out of the application or use of any product or circuit, and specifically disclaims any and all liability, including without limitation consequential or incidental damages. "Typical" parameters that may be provided in Freescale Semiconductor data sheets and/or specifications can and do vary in different applications and actual performance may vary over time. All operating parameters, including "Typicals", must be validated for each customer application by customer's technical experts. Freescale Semiconductor does not convey any license under its patent rights nor the rights of others. Freescale Semiconductor products are not designed, intended, or authorized for use as components in systems intended for surgical implant into the body, or other applications intended to support or sustain life, or for any other application in which the failure of the Freescale Semiconductor product could create a situation where personal injury or death may occur. Should Buyer purchase or use Freescale Semiconductor products for any such unintended or unauthorized application, Buyer shall indemnify and hold Freescale Semiconductor and its officers, employees, subsidiaries, affiliates, and distributors harmless against all claims, costs, damages, and expenses, and reasonable attorney fees arising out of, directly or indirectly, any claim of personal injury or death associated with such unintended or unauthorized use, even if such claim alleges that Freescale Semiconductor was negligent regarding the design or manufacture of the part.

Freescale™ and the Freescale logo are trademarks of Freescale Semiconductor, Inc. All other product or service names are the property of their respective owners.  
© Freescale Semiconductor, Inc. 2006. All rights reserved.

